

O.D. FLASH: 0.015 MAX. (0.4MM)
 GATE VESTIGE: 0.01 MAX. (0.3MM)
 EMBEDDED PARTICLES, BUBBLES, SPOTS, STAINS: 0.3mm² MAX. NO MORE THAN 3 PER PART.

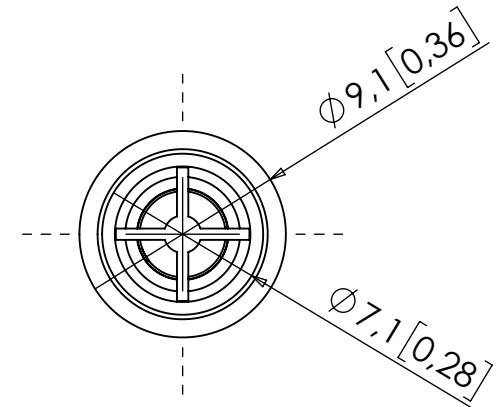

2				16/07/2019	
REV	CREATED	CHECKED	APPROVED	DWG DATE	REF
MATERIAL: PVC, SILICONE, STAINLESS STEEL					
If dimensional information is critical, please contact Eoxshop.com for confirmation. All dimensions are in accordance with the manufacturers drawings and are subject to change without prior notice.				EOXSHOP TEL: +44 (0) 23 9226 6031 WWW.EOXSHOP.COM SALES@EOXSHOP.COM	
TITLE: SHORT BODY LUER CHECK VALVE WITH SPRING, CLEAR PVC					
		DIM'S mm[inch]	SCALE NTS	SIZE A4	SHEET 1 / 1 DOCUMENT NUMBER E-N-190033 REVISION 2

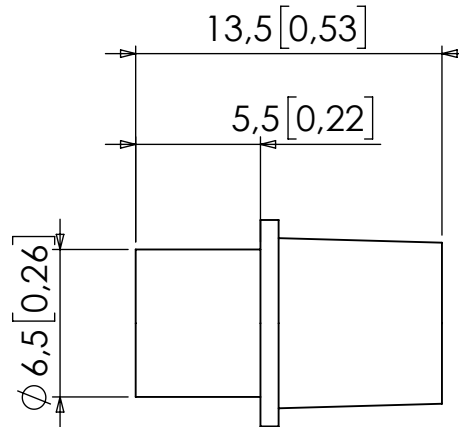